

# The systems approach to microcomputer systems.

**DIODE**

HOLLANTLAAN 22, 3526 AM UTRECHT  
TEL. 030 - 884214 TELEX 47388

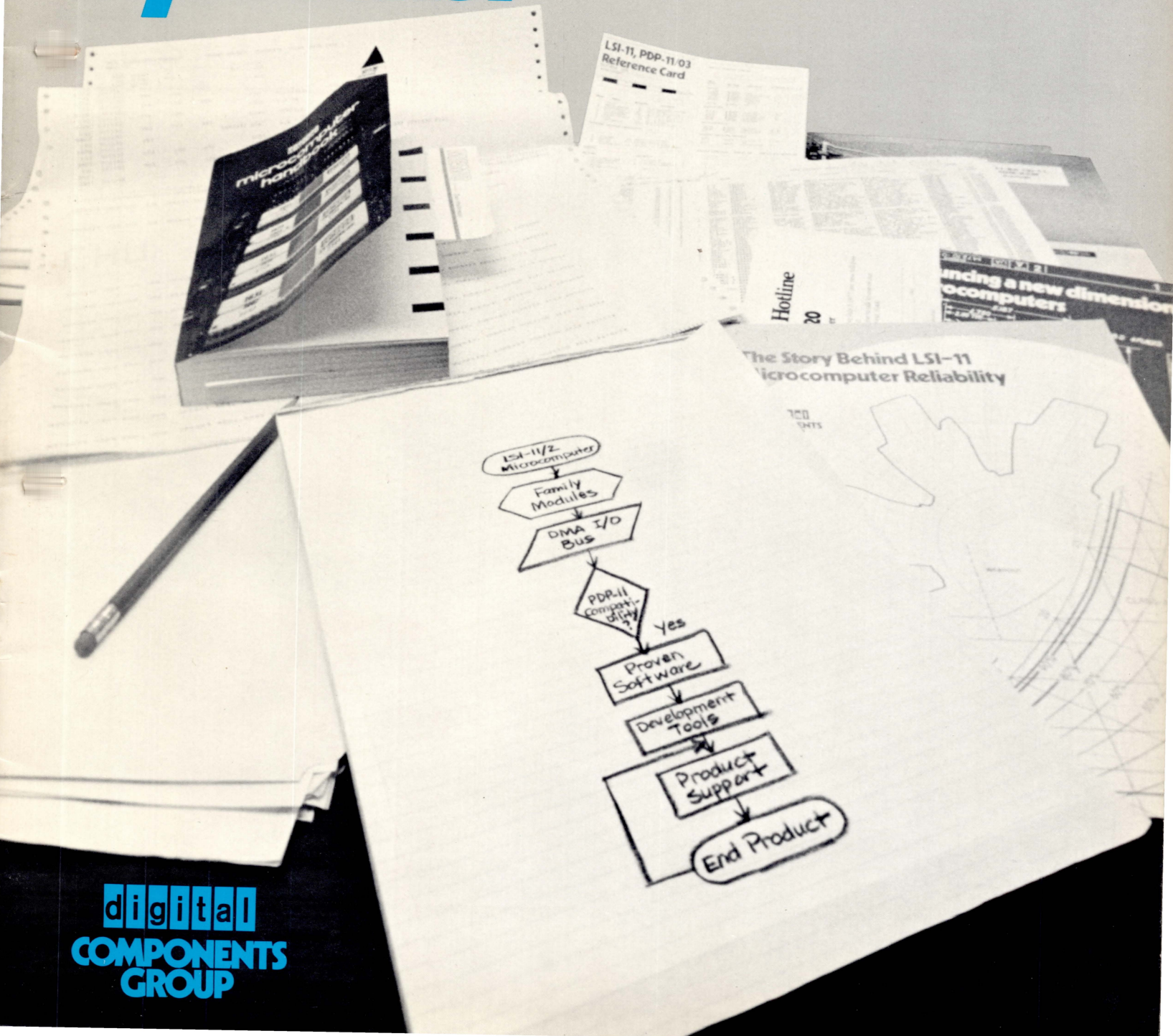

**digital**  
**COMPONENTS**  
**GROUP**

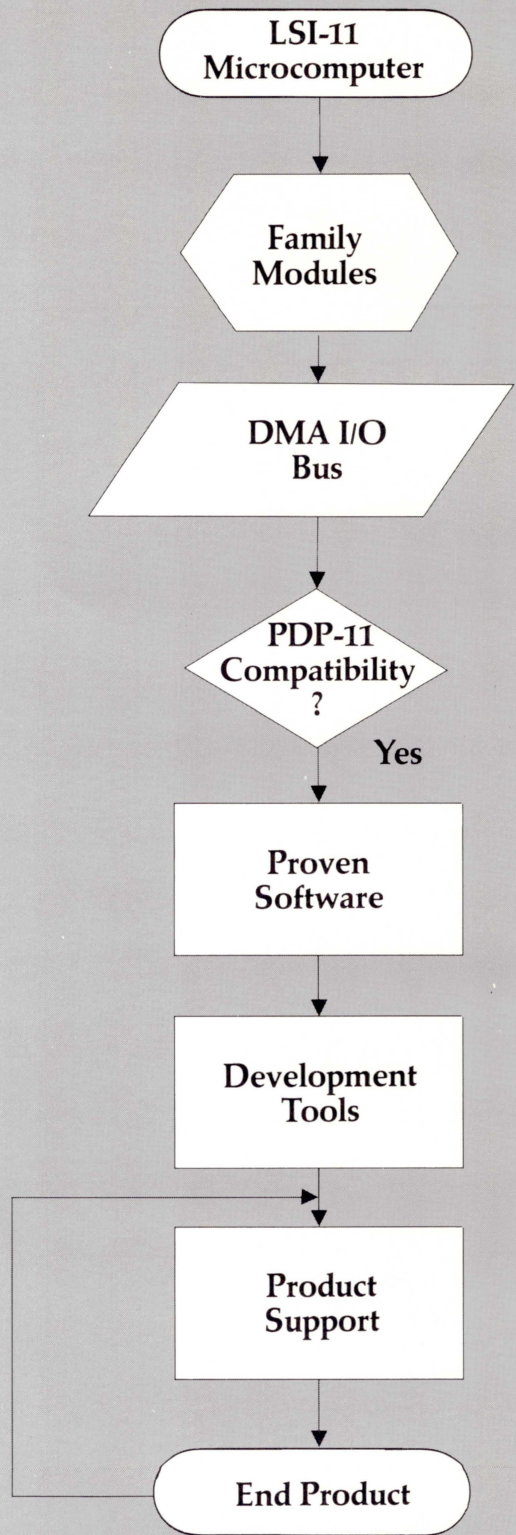

# Contents.

## **LSI-11 microcomputer** ..... 3

The LSI-11 microcomputer contains the power of a minicomputer on your choice of board size: small, or very small.\* Either way, the LSI-11 provides 16-bit word length, eight general registers, word or byte processing, and many other features that make it a good place to start when you want to design computer power into your product. But it's only the beginning of what's available from the Components Group of Digital Equipment Corporation.

## **Configuring your system** ..... 7

You can choose from an entire family of LSI-11 products, all mounted on conveniently sized boards: memory modules, interface modules, even kits for designing your own interfaces. They're designed to work together, and they all interface to the LSI-11 bus, which has inherent DMA capability.

## **Developing your system** ..... 15

When it's time to program your system, you have extensive resources. The LSI-11 instruction set is the same basic instruction set of the most widely used and most widely programmed minicomputers in the world—DIGITAL's PDP-11 family. Software resources are proven and extensive. For the development you still have to do, you can use one of the PDP-11 based development systems that have powerful programming tools to reduce development time.

## **Support** ..... 19

Finally, you have the advantage of doing business with the world's leading interactive computer company, with offices and service centers world-wide.

For an overview of DIGITAL's systems approach, read the introductory sections to each chapter. Then keep this bulletin as a useful reference for the LSI-11, its family modules, software and development systems.

\* LSI-11: 10" x 8½" (26.6cm x 22.8cm) with 4k memory.  
LSI-11/2: 5" x 8½" (13.3cm x 22.8cm) without memory.



CONTROL:

THIS PROGRAM READS THROUGH THE STATED ADDRESS OF THE MEMORY SWITCH REGISTER (RMR) AS LOC. 174 FROM THE 177, AND IS ACCOMPLISHED BY USING THE FOLLOWING:

- 1) TEST CONTROL 0 (70X) THIS WILL ALLOW THE CPU TO SAVE DATA INTO LOC. 176 AT SELECTED POINTS WITHIN THE PROGRAM.
- 2) THE MACHINE WILL THEN TEST: ~~XXXXXXXX~~ ~~HEMT~~ ~~XXXXXX~~ IN THE CIRCULAR CONTENTS OF THE SOFTWARE SWITCH REGISTER.

```

01 00000000 00000000 00000000 00000000
02 00000000 00000000 00000000 00000000
03 00000000 00000000 00000000 00000000
04 00000000 00000000 00000000 00000000
05 00000000 00000000 00000000 00000000
06 00000000 00000000 00000000 00000000
07 00000000 00000000 00000000 00000000
08 00000000 00000000 00000000 00000000
09 00000000 00000000 00000000 00000000
10 00000000 00000000 00000000 00000000
11 00000000 00000000 00000000 00000000
12 00000000 00000000 00000000 00000000
13 00000000 00000000 00000000 00000000
14 00000000 00000000 00000000 00000000
15 00000000 00000000 00000000 00000000
16 00000000 00000000 00000000 00000000
17 00000000 00000000 00000000 00000000
18 00000000 00000000 00000000 00000000
19 00000000 00000000 00000000 00000000
20 00000000 00000000 00000000 00000000
21 00000000 00000000 00000000 00000000
22 00000000 00000000 00000000 00000000
23 00000000 00000000 00000000 00000000
24 00000000 00000000 00000000 00000000
25 00000000 00000000 00000000 00000000
26 00000000 00000000 00000000 00000000
27 00000000 00000000 00000000 00000000
28 00000000 00000000 00000000 00000000
29 00000000 00000000 00000000 00000000
30 00000000 00000000 00000000 00000000
31 00000000 00000000 00000000 00000000
32 00000000 00000000 00000000 00000000
33 00000000 00000000 00000000 00000000
34 00000000 00000000 00000000 00000000
35 00000000 00000000 00000000 00000000
36 00000000 00000000 00000000 00000000
37 00000000 00000000 00000000 00000000
38 00000000 00000000 00000000 00000000
39 00000000 00000000 00000000 00000000
40 00000000 00000000 00000000 00000000
41 00000000 00000000 00000000 00000000
42 00000000 00000000 00000000 00000000
43 00000000 00000000 00000000 00000000
44 00000000 00000000 00000000 00000000
45 00000000 00000000 00000000 00000000
46 00000000 00000000 00000000 00000000
47 00000000 00000000 00000000 00000000
48 00000000 00000000 00000000 00000000
49 00000000 00000000 00000000 00000000
50 00000000 00000000 00000000 00000000
51 00000000 00000000 00000000 00000000
52 00000000 00000000 00000000 00000000
53 00000000 00000000 00000000 00000000
54 00000000 00000000 00000000 00000000
55 00000000 00000000 00000000 00000000
56 00000000 00000000 00000000 00000000
57 00000000 00000000 00000000 00000000
58 00000000 00000000 00000000 00000000
59 00000000 00000000 00000000 00000000
60 00000000 00000000 00000000 00000000
61 00000000 00000000 00000000 00000000
62 00000000 00000000 00000000 00000000
63 00000000 00000000 00000000 00000000
64 00000000 00000000 00000000 00000000
65 00000000 00000000 00000000 00000000
66 00000000 00000000 00000000 00000000
67 00000000 00000000 00000000 00000000
68 00000000 00000000 00000000 00000000
69 00000000 00000000 00000000 00000000
70 00000000 00000000 00000000 00000000
71 00000000 00000000 00000000 00000000
72 00000000 00000000 00000000 00000000
73 00000000 00000000 00000000 00000000
74 00000000 00000000 00000000 00000000
75 00000000 00000000 00000000 00000000
76 00000000 00000000 00000000 00000000
77 00000000 00000000 00000000 00000000
78 00000000 00000000 00000000 00000000
79 00000000 00000000 00000000 00000000
80 00000000 00000000 00000000 00000000
81 00000000 00000000 00000000 00000000
82 00000000 00000000 00000000 00000000
83 00000000 00000000 00000000 00000000
84 00000000 00000000 00000000 00000000
85 00000000 00000000 00000000 00000000
86 00000000 00000000 00000000 00000000
87 00000000 00000000 00000000 00000000
88 00000000 00000000 00000000 00000000
89 00000000 00000000 00000000 00000000
90 00000000 00000000 00000000 00000000
91 00000000 00000000 00000000 00000000
92 00000000 00000000 00000000 00000000
93 00000000 00000000 00000000 00000000
94 00000000 00000000 00000000 00000000
95 00000000 00000000 00000000 00000000
96 00000000 00000000 00000000 00000000
97 00000000 00000000 00000000 00000000
98 00000000 00000000 00000000 00000000
99 00000000 00000000 00000000 00000000
100 00000000 00000000 00000000 00000000

```

3-8

3.3.8 Charge Pump Circuit

The charge pump circuit produces the +5V operating power for the PROMS across the backplane. The basic components comprising the charge pump circuit are shown in Figure 3-2. A positive signal from the +12V present on the LSI-11 backplane. Hence, the MN1118A requires some external power other than the usual +5V and +12V present on the backplane.

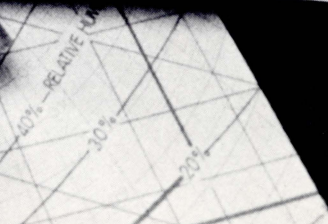
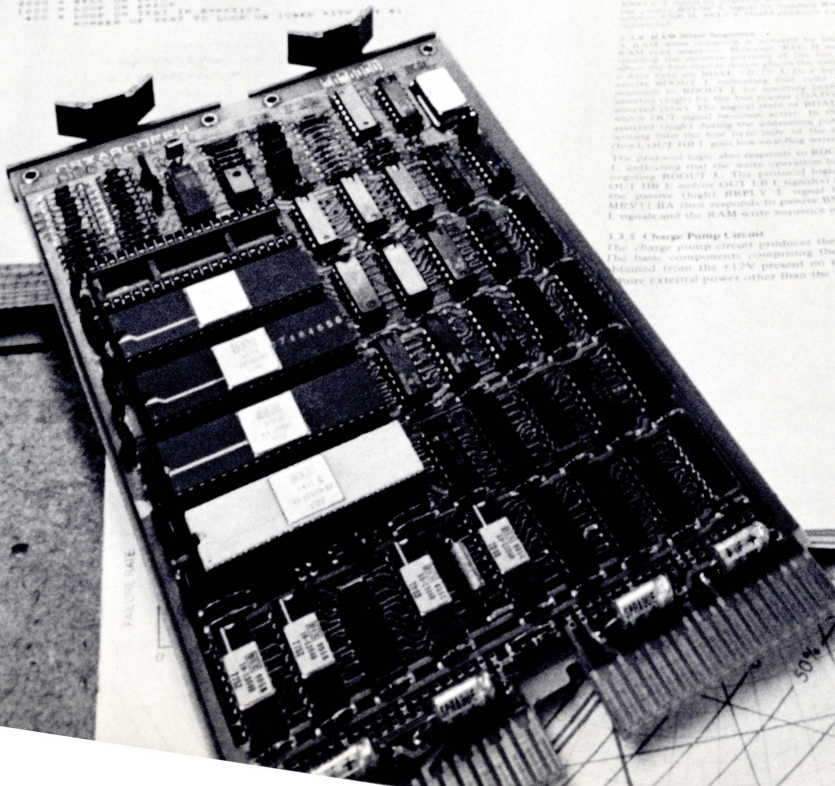

# The LSI-11 microcomputer.

The LSI-11 provides much greater power than you could get on a chip, yet because it's an unbundled board you retain the packaging flexibility you need for your finished product.

On one board you get an N-channel MOS central processor (380ns cycle time), 16-bit word length with bit, byte, word and multiword processing, direct memory addressing up to 32K words, real-time clock input, and power fail/auto restart. The LSI-11 can be equipped with various options for still higher performance, such as a floating-point instruction set.

The power of the LSI-11 is very much at your disposal. There are eight general registers that you can use for a variety of purposes. And the LSI-11 bus makes system configuration simple and powerful.

The LSI-11 also provides other benefits, such as proven reliability. The microcomputer undergoes an exacting manufacturing and testing process—at the component level and at the board level—so that the problems usually associated with a product's early use are eliminated. For details on DIGITAL's reliability program, ask for our brochure, "The Story Behind LSI-11 Microcomputer Reliability."

## LSI-11 microcomputer (KD11-F, KD11-HA)

The LSI-11 microcomputer comes in two versions. The KD11-F is mounted on a 10" x 8½" (26.6cm x 22.8cm) board, with a 4K RAM memory. For packaging flexibility, the KD11-HA is offered without on-board memory, on a 5" x 8½" (13.3cm x 22.8cm) board.

Also available is the LSI-11 in a box—the PDP-11/03, with an enclosure and power supply, lights, switches, and fan.

The LSI-11 microcomputer offers the following features.

**16-bit central processor.** The 16-bit architecture of the LSI-11 offers distinct advantages over 8-bit devices. It means easier programming and higher throughput, because less code is required for each operation.

The CPU functions are contained in four silicon gate N-channel MOS integrated circuit chips. These chips provide all instructions, decoding, bus control, and arithmetic/logic unit functions of the processor. The CPU's eight registers can be used as accumulators, address pointers, index registers, and other specialized functions.

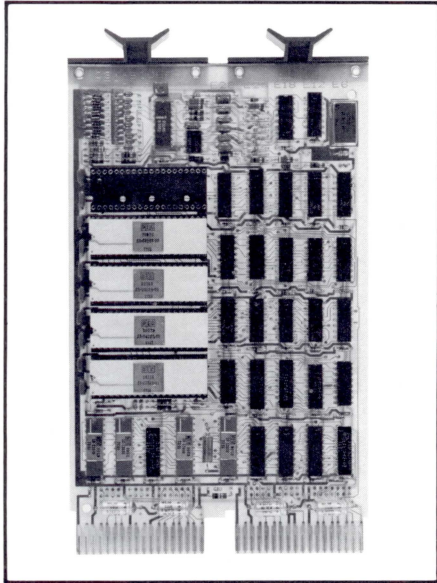

LSI-11/2 CPU

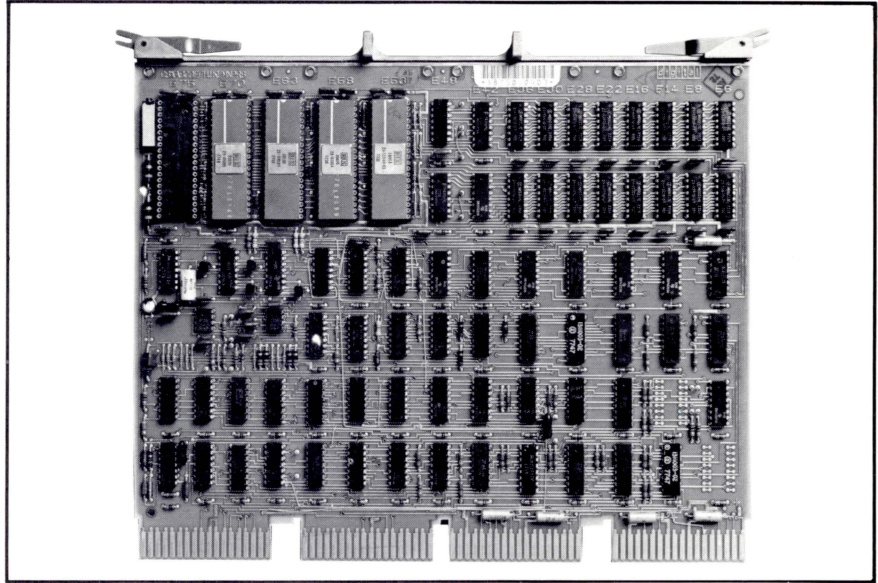

LSI-11 CPU  
with 4K memory

**PDP-11 instruction set.** More than 400 powerful instructions make up the LSI-11's basic instruction set. The same instructions are used for memory, I/O or accumulator operations, so data in peripheral device registers can be manipulated as flexibly as data in memory registers. For example, the processor can directly modify or test data in a peripheral's registers, without bringing the data into memory or the accumulators.

The basic operation code uses both single- and double-operand instructions for words (16 bits) or bytes (8 bits), making it possible to perform such operations as adding, subtracting, or moving two operands in one step. This can reduce the number of instructions needed for many routines by as much as two thirds.

**Addressing flexibility.** Much of the LSI-11's operating flexibility and processing power are derived from its wide variety of addressing techniques. Addressing can be direct, indirect, autoincrement, autodecrement, byte or word, indexing or stack addressing.

This flexibility means the LSI-11 can deal with data in the most efficient manner.

**DMA I/O bus.** The LSI-11 bus provides a vectored, priority-structured interrupt system for DMA and programmed I/O transfers. All modules operate asynchronously, permitting each to function at its highest speed. See the next section for details on the LSI-11 bus.

**Real-time clock input.** One signal line is reserved as an external interrupt line. When connected to a clock, it serves as a real-time processor interrupt. A jumper on the microcomputer enables or disables this highest priority function.

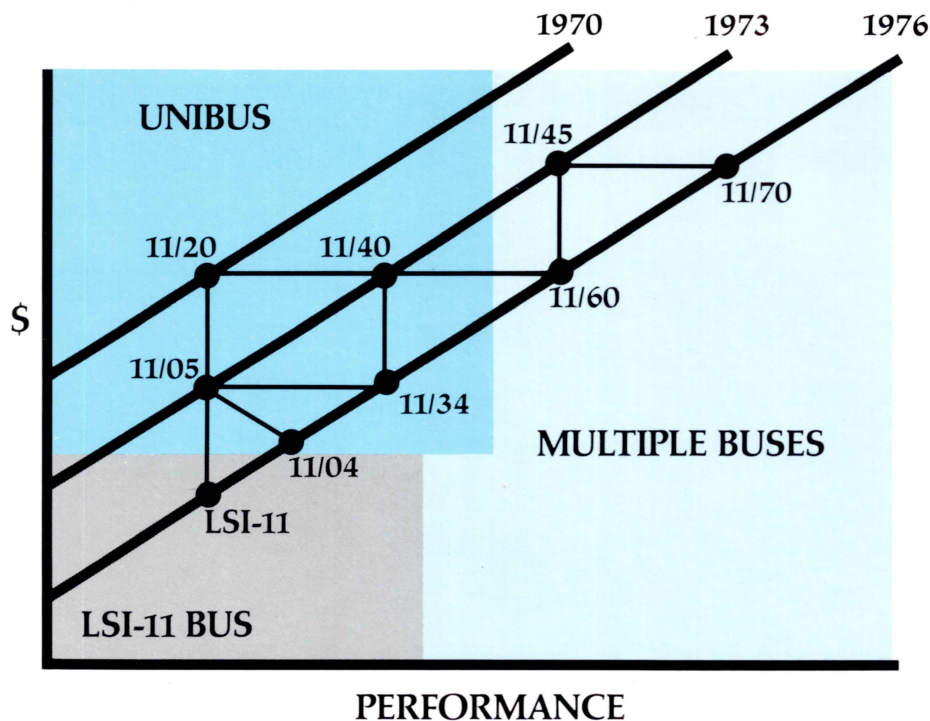

**PDP-11 family history.** The LSI-11 continues the cost/performance advance of the PDP-11 family. But while technology improves, the family keeps its compatibility by incorporating the same basic instruction set. Any software written for the LSI-11 is upward compatible with any of the other PDP-11 CPUs.

**Power fail/auto restart.** Power failure is one of a series of conditions causing the central processor to trap to a set of fixed locations.

Whenever dc power sequencing signals indicate an impending ac power loss, a microcoded power-fail sequence is initiated. The microcomputer traps to a defined location to execute a user's power-down routine, for an orderly system shut-down.

Jumper-selectable restart is possible through a power-up vector, standard bootstrap location, octal debugging technique (ODT), or user microcode.

**ODT/ASCII console routine/bootstrap.** These are all resident in microcode to provide automatic entry into the debugging mode and to automatically commence operation through resident bootstrap routines. This also allows conventional programmer's panel lights and switches to be replaced by any terminal device generating standard ASCII code.

**Extended arithmetic option.** This option, contained on a chip, allows extended manipulation of fixed-point numbers (fixed-point arithmetic), and enables direct operations on single-precision 32-bit words (floating-point arithmetic).

Fixed point instructions:

<i>Mnemonic</i>	<i>Instruction</i>
MUL	Multiply
DIV	Divide
ASH	Shift arithmetically
ASCH	Arithmetic shift combined

Floating point instructions:

FADD	Floating add
FSUB	Floating subtract
FMUL	Floating multiply
FDIV	Floating divide

**Writable Control Store option.** This option lets you expand the instruction set of the LSI-11 for higher performance in time-critical applications.

You can use the option to create new instructions and add them to the basic instruction set. The result is an enhanced instruction set designed by you for your specific application.

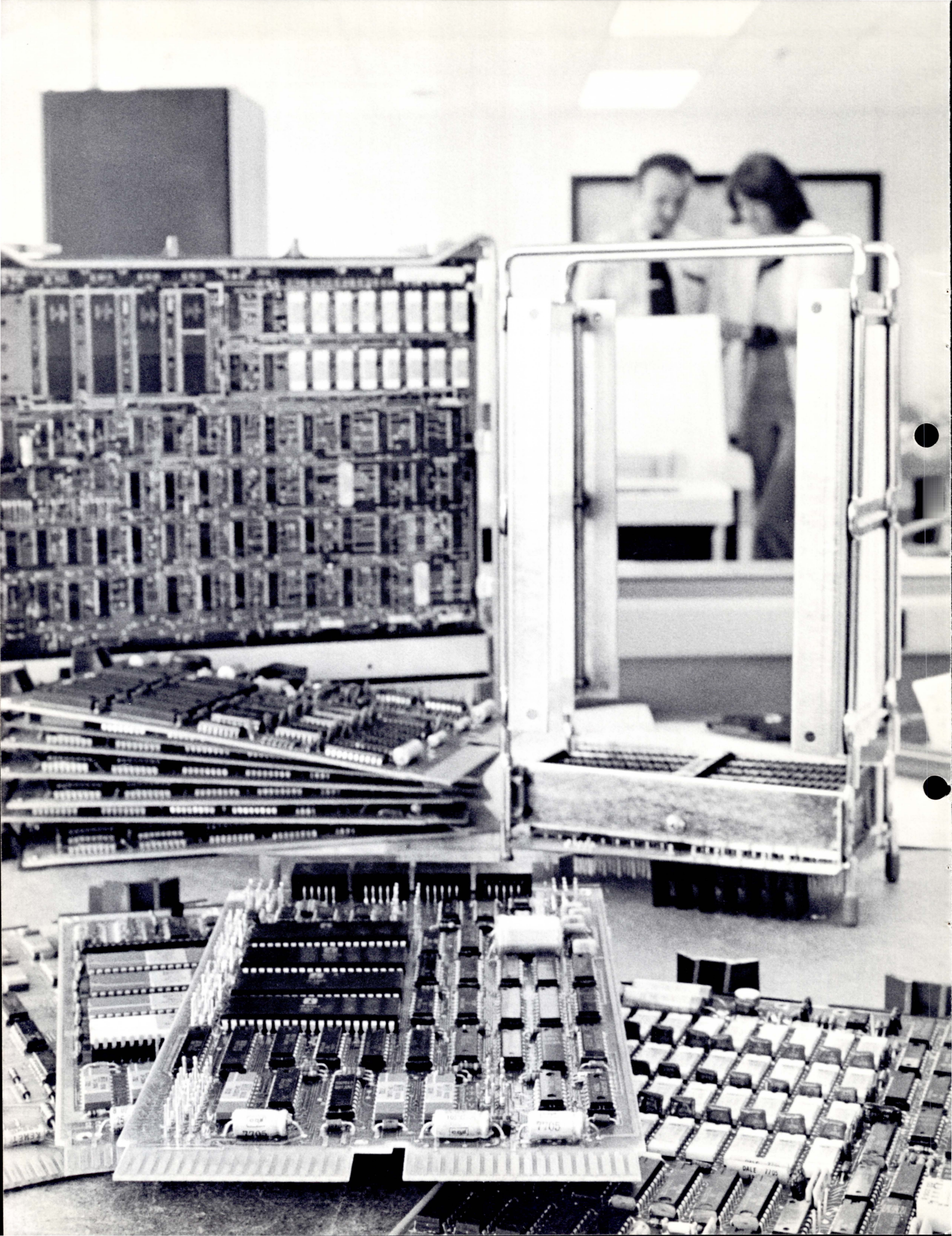

# Configuring your system.

Once you have an LSI-11 microcomputer, a whole range of configuration possibilities is available to you. This versatility stems from the complete family of memory and interface modules designed for the LSI-11 and the simple, effective LSI-11 bus.

The LSI-11 family modules provide several advantages. For one, they are all contained on small-size boards, which gives you an exceptionally powerful system in very little space. Also, you have a wide choice: RAM memory modules from 4K words to 32K words, serial and parallel line interfaces, and a CHIPKIT—complete with instructions—for designing your own LSI-11 interface. Of course, the modules are designed, built and tested by Digital Equipment Corporation, so they're finely tuned to work together for optimum performance.

Another key to configuration flexibility is the LSI-11 bus. Not only is it easy to use—you simply plug the modules into the backplane containing bus wiring—but it's also an effective way to put together a system. Each device performs DMA and programmed I/O transfers at its maximum rate, rather than at a rate defined by the processor.

This chapter explains how the LSI-11 bus operates, and describes the various modules available for configuring your LSI-11 system.

## The LSI-11 bus

**Bus concept.** All communication between modules in an LSI-11 system takes place on a single unified bus. Unified means that one bus connects both the memory elements and the I/O interface and control elements to the LSI-11 processor, so the same instructions can be used for handling both elements. I/O control and data registers are mapped into the standard 32K word address range.

Address information is time-multiplexed on the same 16-line bidirectional bus. The processor first places the address of the desired memory location or I/O interface register on the bus, and then follows with control signals that indicate that the address is valid. After that, additional control signals indicate the direction of data flow. The addressed module interprets the control signal and responds either by accepting data transmitted from the processor, or by transmitting data to the processor.

This operation is asynchronous because the address device does not have to respond to the processor at a specific speed. Instead, every module can be optimized for its own performance without being limited by the operating speed of other devices on the bus.

The LSI-11 bus provides a fully vectored, prioritized interrupt scheme, with a nearly unlimited number of independent interrupts in a system. Every interrupt stimulus can have its own vector and interrupt service routine, eliminating the need to poll I/O devices to find the source of an interrupt. Priority of I/O devices is determined by position on the bus—the closer a device is to the processor, the higher its priority. The processor can enable or disable all interrupts in the system, or it can enable or disable interrupts for a particular device through individual control and status registers.

A device initiates an interrupt by asserting the interrupt request signal line on the bus. The processor monitors the line and responds, after concluding the current instruction, by issuing an interrupt grant. This grant is daisy-chained down the LSI-11 bus until it reaches the first module with an asserted interrupt request. This module responds by placing a vector on the bus, which the processor uses as the pointer to memory locations containing the starting address of the interrupt service routine and the processor status that will be used in conjunction with the interrupt service routine.

If faster data transfer is required, the I/O interface module may use standard Direct Memory Access (DMA) techniques. During DMA operation, the I/O device interface actually controls the bus address and control signals in exactly the same way as the processor. It gains control by making a request on the DMA request line on the bus. The processor issues a DMA grant as soon as the current bus operation is complete, rather than waiting to complete the current instruction. This means a Direct Memory Access takes place entirely transparent to the execution of the normal program. Like the interrupt grant, the DMA grant is daisy-chained down the bus, which means priority is determined by a module's physical proximity to the processor.

Altogether, the LSI-11 bus contains 16 data/address lines and 17 control/synchronization signal lines. For more LSI-11 bus details, see Chapter 3 of the LSI-11 Microcomputer Handbook.

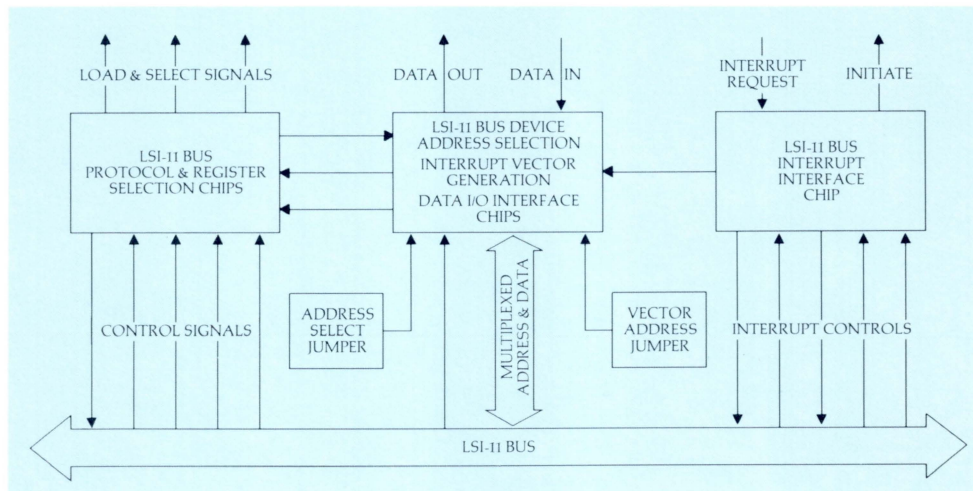
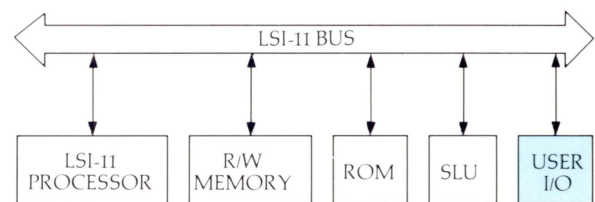

Bus interface example

**Backplane/card guide assembly.** The backplane and card guide assembly contains the LSI-II bus in a convenient package. All bus data, control, and power connections are prewired on the printed circuit backplane to each module location. Placing a module into the backplane automatically passes the bus grant signal to the next, lower priority device. The backplane supports battery backup, and is available in six versions.

The H9270 backplane can be used for either the 10" x 8 1/2" modules, or the 5 1/2" x 8 1/2" modules. It has a 4 x 4 configuration (four slots wide and four slots deep), and can be expanded with additional H9270 backplanes when more module space is required.

The H9281 backplane is for the smaller modules only, with configurations of 2 x 4, 2 x 8, or 2 x 12.

**Power supply.** The H780 power supply for the backplane assembly provides for the standard system power supply voltages (+5V and +12V). In addition, it has built-in fans for cooling all components, generates line-time clock signals for the event interrupt line, monitors power supply status for the processor's power fail/auto restart logic, and protects against overcurrent and overvoltage conditions.

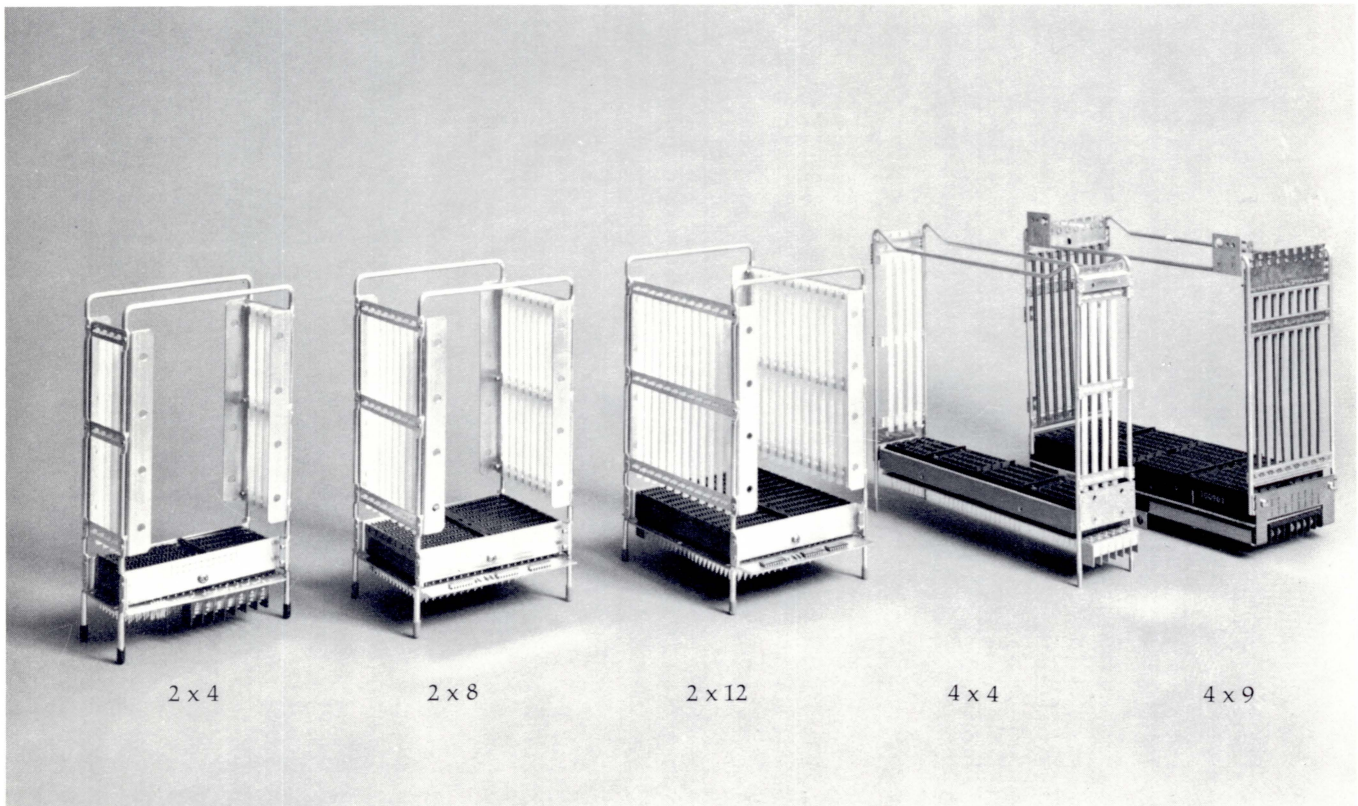
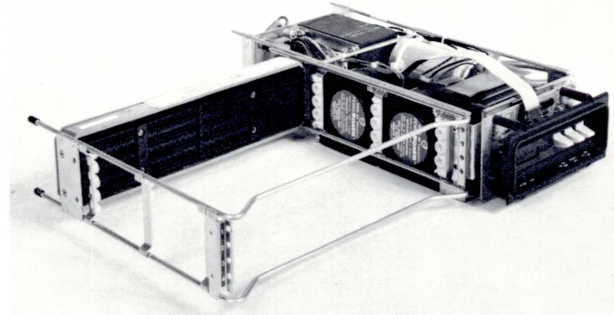

Backplane and card guide assemblies

## Family modules

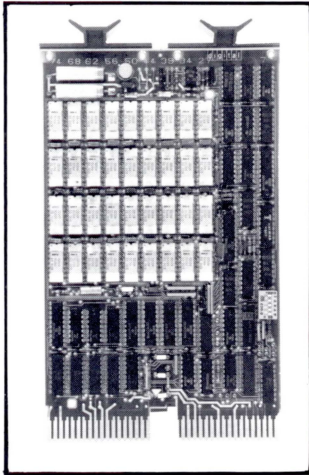

Dynamic MOS RAM memory

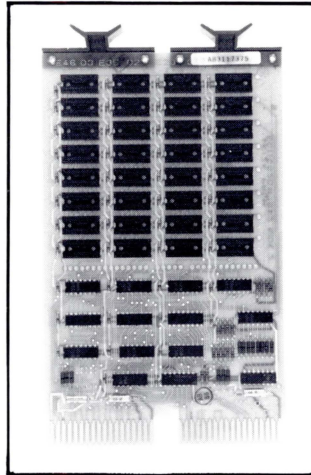

4K PROM memory

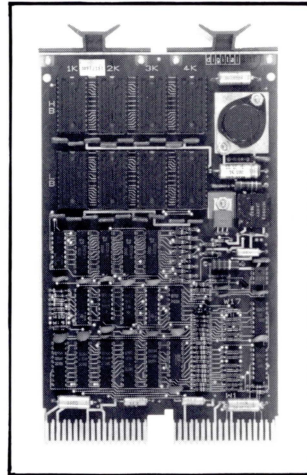

UV PROM/RAM memory

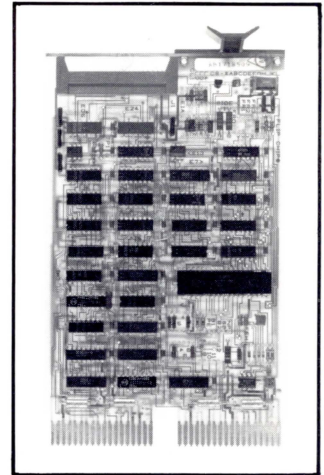

Single-line serial interface

**Dynamic MOS RAM memory, 4K to 32K (MSV11-D).** 16-bit read/write memory modules, with 4K, 8K, 16K or 32K words of memory are available. Designed for high performance in LSI-11 systems, these modules have an access time of 240ns, and address decode circuitry can be set to start on any 4K address boundary. Up to 30K words of the 32K module can be used in an LSI-11 system.

Dynamic memory refresh is performed automatically every 1.67 milliseconds by logic located on the memory boards. Memory contents may be protected by a user-implemented battery back-up power source.

Optionally available are the same basic modules with byte parity.

All MSV11-D memory modules are contained on 5" x 8½" (13.3cm x 22.8cm) boards.

**4K PROM memory (MRV11-AA).** This field-programmable, read-only module utilizes either 256 x 4 or 512 x 4 fusible-link semi-conductor devices. The module's maximum capacity is 2048 or 4096 words of 16 bits (depending upon which device is used), and is expandable in 256- or 512-word increments. 32 sockets are provided for mounting memory IC devices, with PROM chips offered as options. Module size: 5" x 8½" (13.3cm x 22.8cm).

A pin-compatible masked ROM chip can be used for volume applications so that the lowest possible cost can be achieved.

**UV PROM/RAM memory (MRV11-BA).** This module provides a 256-word static RAM memory, plus eight sockets for installing up to 4K words of nonvolatile PROM chips. Each optional PROM chip is 1K x 8-bit. PROMs can be erased by exposure to high-intensity ultra-violet light, and then reprogrammed. Jumper locations on the module allow independent selection of system memory starting addresses for RAM and PROM memory functions.

Module size: 5" x 8½" (13.3cm x 22.8cm).

**Single-line serial interface (DLV11).** The DLV11 is a universal, asynchronous receiver/transmitter serial interface module for use between the LSI-11 bus and serial devices. Straps select either a 20mA current loop or EIA interface. Baud rates are selectable: 50, 75, 110, 134.5, 150, 200, 300, 600, 1200, 1800, 2400, 4800 and 9600 baud.

The module contains LSI-11 bus interface logic and control logic for interrupt generation for both receive and transmit channels.

Module size: 5" x 8½" (13.3cm x 22.8cm).

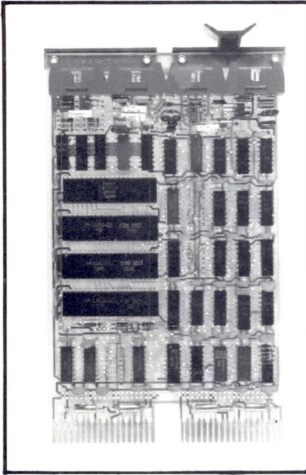

Four-line serial interface

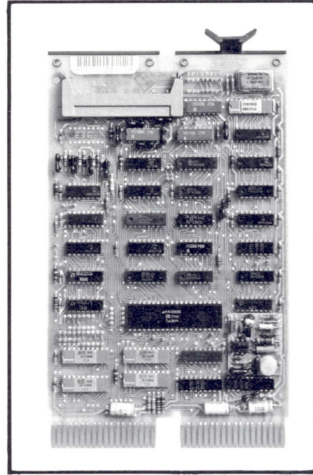

Bus/modem serial interface

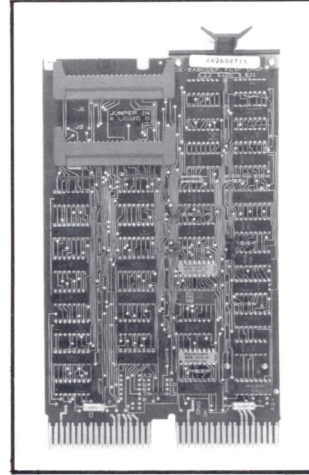

Parallel line interface

**Four-line serial interface (DLV11-J).** The DLV11-J interfaces four asynchronous serial lines to the LSI-11 bus, with the fourth channel capable of interfacing with a console device. Each channel may be separately configured, using wire wrap jumpers, for stop and data bits, parity, and baud rates (150, 300, 600, 1200, 2400, 4800, 9600, 19200, and 38400 baud).

Enhanced EIA specifications (RS422/423), compatible with RS232, allow increased drive capability—4K feet at 38.4 kilobaud. A 20mA option is available to convert the EIA; one is needed for each channel.

The module contains LSI-11 bus interface logic and control logic for interrupt generation for both receive and transmit channels.

Module size: 5" x 8½" (13.3cm x 22.8cm).

**Bus/modem serial interface (DLV11-E).** This asynchronous, serial line module interfaces the LSI-11 bus with modems having control capability, such as BELL models 103, 202C, and 202D. It provides jumper-selectable parity and data bits, and jumper- or program-selectable baud rates (50, 75, 110, 134.5, 150, 300, 600, 1200, 1800, 2000, 3600, 7200, and 9600 baud).

The module contains LSI-11 bus interface logic and control logic for interrupt generation for both receive and transmit channels.

Module size: 5" x 8½" (13.3cm x 22.8cm).

**Bus/modem serial multiplexer (DZV11).** The DZV11 interfaces the LSI-11 bus with up to four asynchronous data communications channels. But unlike the DLV11-J, this module multiplexes four lines that are controlled by one set of registers. Each channel operates under program control, with independent baud rates, character length, stop bits, and parity generation and detection.

The module provides EIA interface levels, and enough data set control to permit automatic operation with full-duplex modems such as BELL models 103, 113, or 212.

Module size: 10" x 8½" (26.6cm x 22.8cm).

**Synchronous line interface (DUV11).** The DUV11 is a single-line, program-controlled, double-buffered communication interface that establishes a data communication line between the LSI-11 microcomputer and a BELL 201 or equivalent modem. The module provides serial-to-parallel and parallel-to-serial data conversion, EIA-to-TTL level conversion, and modem control for full- or half-duplex communication systems.

In addition, the DUV11 handles synchronous or isochronous communication data, generates and verifies a parity bit, and handles variable length characters (5, 6, 7 or 8 bits, plus parity).

Module size: 10" x 8½" (26.6cm x 22.8cm).

**Parallel line interface (DRV11).** This general-purpose, 16-bit unit interfaces the LSI-11 bus with a TTL or DTL logic-compatible parallel peripheral device. Four control lines to the peripheral indicate output data ready, output data accepted, input data ready, and input data accepted logic operations. The module provides a maximum data transfer rate of 90K words per second under program control, and a maximum drive capability of 25 feet (7.6 meters) of cable.

The DRV11 contains LSI-11 bus interface logic and control logic for interrupt generation for both receive and transmit channels.

Module size: 5" x 8½" (13.3cm x 22.8cm).

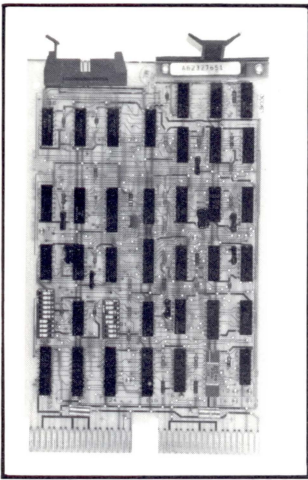

IEEE instrument  
bus interface

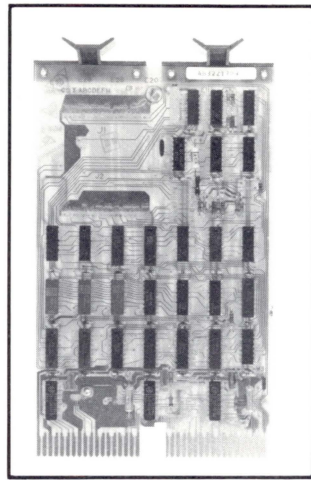

Terminator bootstrap  
ROM & DMA refresh

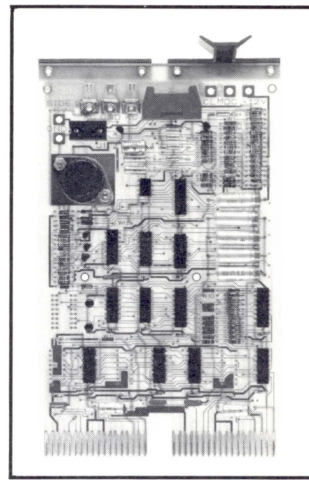

Power fail/line time  
clock generator

**DMA interface (DRV11-B).** This module is a general-purpose DMA interface for transferring 16-bit data words directly between the LSI-11 memory and a user's I/O device. Burst modes, byte addressing, and read-modify-write operation are possible with the DRV11-B.

The module features buffered I/O data, and switch-selectable device address and interrupt vector address. Module size: 10" x 8½" (26.6cm x 22.8cm).

**Analog-to-digital converter (ADV11-A).** The ADV11-A is a 12-bit, successive-approximation, analog-to-digital converter with built-in multiplexer and sample-and-hold for use on the LSI-11 bus. The multiplexer section accommodates 16 single-ended or 8 quasi-differential inputs, and the converter section utilizes a patented auto-zeroing design that effectively cancels out its own offset error contributions to the measurement.

A vernier offset digital-to-analog converter is included in the ADV11-A's analog circuitry. Three test signals—two dc levels and one bipolar triangular waveform—are available for use on any channel input. The triangular wave can be used in conjunction with diagnostic software and the vernier DAC to produce extremely thorough and precise analog testing.

Module size: 10" x 8½" (26.6cm x 22.8cm).

**Four-channel 12-bit D/A converter (AAV11-A).** This module includes control and interfacing circuitry, four D/A converters, a dc-dc converter to provide power to the analog circuits, and voltage reference. Each channel provides 12 bits of resolution, and each has its own holding register which can be separately addressed and can be written and read in either word or byte format.

The AAV11-A's four input channels are binary encoded for either unipolar or bipolar mode, and output ranges and modes are jumper-selectable.

Module size: 10" x 8½" (26.6cm x 22.8cm).

**Programmable real-time clock (KWV11-A).** The KWV11-A can be used to generate interrupts to the LSI-11 processor at predetermined intervals, to synchronize the processor to external events, or to measure time intervals or establish programmed ratios between input and output events. It can be operated in any of four programmable modes: single interval, repeated interval, external event timing, and external event timing from zero base.

The clock counter has a resolution of 16 bits and can be driven from any of five internal crystal-controlled frequencies (100 Hz to 1 MHz), from a line frequency input, or from a Schmitt trigger fired by an external input.

Module size: 10" x 8½" (26.6cm x 22.8cm).

**IEEE instrument bus interface (IBV11-A).** The IBV11-A interfaces the LSI-11 bus to the IEEE 488 instrument bus, making possible a low-cost, programmable instrumentation system. The module can control 15 instruments, such as signal generators, digital voltmeters and frequency output counters, on a bus cable length of up to 65 feet (20 meters).

Board mounted switches permit easy device address and interrupt vector address selection. Self-diagnostic routines are included.

Module size: 5" x 8½" (13.3cm x 22.8cm).

**Terminator bootstrap ROM & DMA refresh (REV11).** This multiple-function module includes circuitry to refresh MOS RAM via DMA cycles. Two versions are available: one with 120 ohm bus terminators (REV11-A), and one without terminating networks (REV11-C).

Both versions include DMA dynamic MOS RAM refresh, bootstrap ROM for DIGITAL's RXV11 floppy disk, diagnostic programs for checking memory and processor operation, and absolute loader programs.

Module size: 5" x 8½" (13.3cm x 22.8cm).

**Bootstrap diagnostic module (BDV11).** The BDV11 is a bootstrap diagnostic and user program loading device for the LSI-11 bus. All functions of the module are switch-selectable, permitting unattended power-up diagnostic and program load operations. Bootstraps are included for the RXV21 double-density floppy and RLV11 5.2 megabyte cartridge disks, DLV11-E asynchronous serial line unit, and DUV11 synchronous serial line unit.

The BDV11 can be used to load up to 3K words of user program automatically on power up. The 2K word ROM supplied with this module contains diagnostics for the CPU, the memory, and the serial line unit.

Module size: 10" x 8½" (26.6cm x 22.8cm).

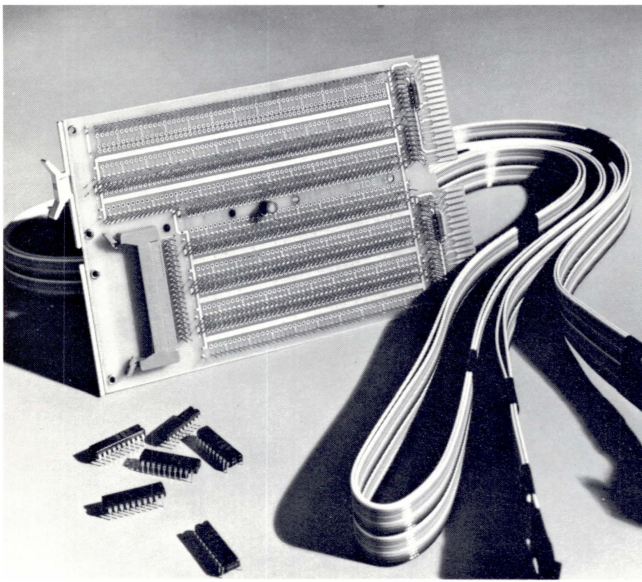

Interface design CHIPKIT

**Power fail/line time clock generator (KPV11).** The KPV11 provides automatic generation of power-up/power-down signal sequence and automatic program restoration and starting when used with non-DIGITAL power supplies. It may be mounted on the LSI-11 backplane, or installed remotely using an optional cable. Also available is an optional console panel for manual control of line time clock and power signal generation, and display of dc power on/off status and processor run/halt state.

Module size: 5" x 8½" (13.3cm x 22.8cm).

**Interface design CHIPKIT (DCK11-AA).** The DCK11-AA supplies the logic necessary for a user to design a custom program transfer interface to the LSI-11 bus. The basic CHIPKIT consists of six chips, which provide bus address decoding, interrupt vector generation, bus drive/receive, and LSI-11 bus protocol logic. The specific chips are:

- |   |       |   |
|---|-------|---|
| 1 | DC003 | Interrupt                                 |
| 1 | DC004 | Protocol                                  |
| 4 | DC005 | Transceiver/address decoder/vector select |

A typical application of a CHIPKIT is presented in the figure below. In this application, the logic consists of bus transceivers, a device address comparator, protocol logic, interrupt logic, vector address generator, and bus receiver and inverter.

Module size: 5" x 8½" (13.3cm x 22.8cm).

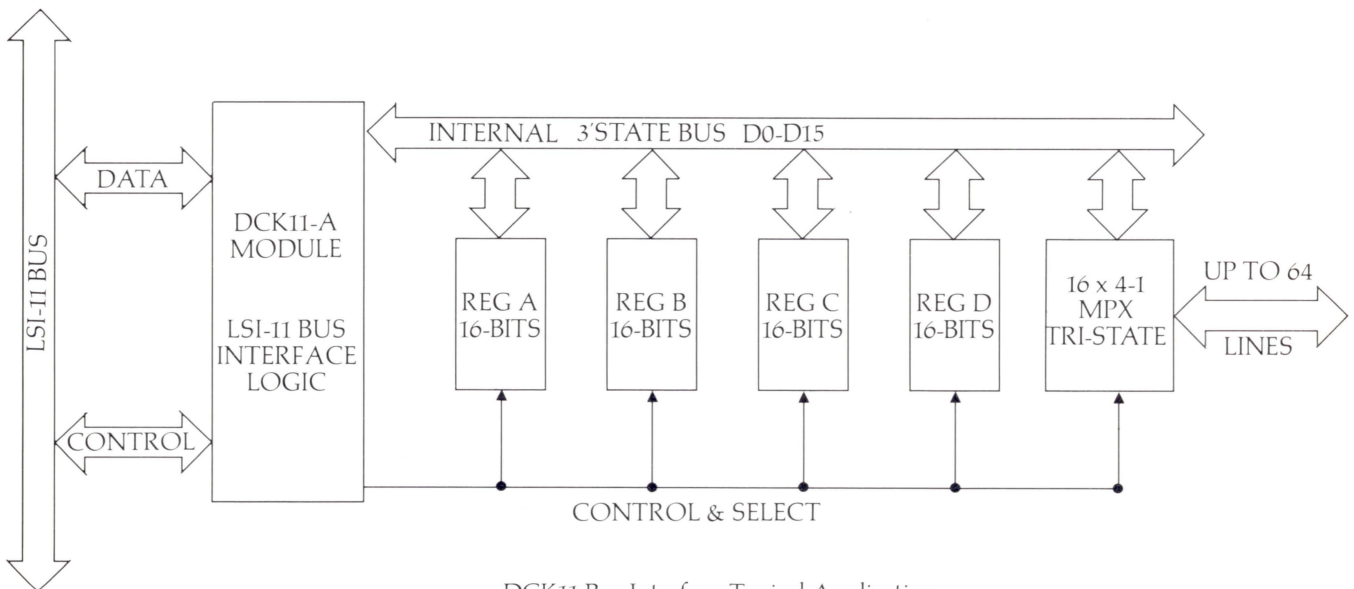

DCK11 Bus Interface Typical Application



# Developing your system.

The LSI-11 microcomputer brings with it unique opportunities for rapid, effective program development.

Its instruction set is the most widely known mini-computer instruction set in the world—that of the PDP-11 minicomputer family.

Its development systems—PDP-11 based, of course—have development tools that are unmatched: high-level FORTRAN that has been developed and enhanced for eight years, plus BASIC, APL and FOCAL; powerful editors and debuggers that work interactively, reducing programming time. Because DIGITAL's development systems are disk-based, you can load or compile programs in seconds. And once you have one of these inexpensive systems, you can use it for general computational work in your business: engineering design/modelling, or specification and documentation work.

For application programming on your LSI-11, you have software packages such as RT-11 run-time system, file handling facilities, real-time multi-tasking and input/output utilities and other PDP-11 software.

Drawing on the development assistance offered by DIGITAL, you can get your LSI-11 based product to market quickly, and at a lower cost to you.

The  
Microcomputer  
Software  
Development  
Process

And  
Digital's  
Tools

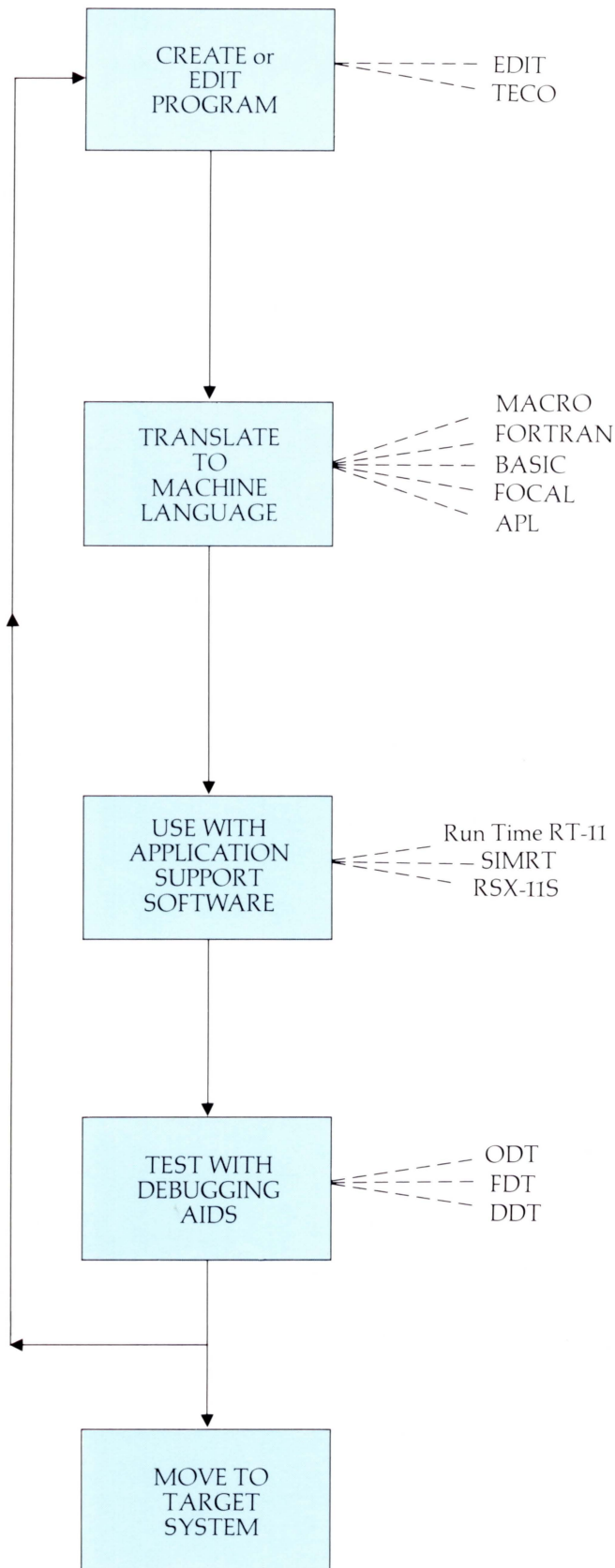

## Development tools

**RT-11 development software.** DIGITAL's development systems run the RT-11 operating system, which has many standard software facilities for making programming simple and effective. RT-11's command language is very approachable: to compile a program, for instance, you write "COMPILE PROGRAM." The software comes with two editors and a debugging facility (described below), MACRO-11 assembler, and support for a wide choice of high-level, industry standard languages.

RT-11 is a floppy-disk based, single-user, foreground/background system. It can support real-time job execution in the foreground, while simultaneously doing an interactive or batch program development job in the background.

**Two powerful editors.** Because much of a programmer's time is spent editing and tuning programs, DIGITAL provides LSI-11 users with state-of-the-art editing capabilities.

Two editors are available. EDIT, an on-line facility, is a simple, easy-to-use, character-oriented editor for occasional or novice users.

A second on-line editor, TECO, is one of the most powerful editors ever offered. The programmer can use it to perform complex editing functions rapidly, in concise groups of TECO commands. It's also a programmable editor, which means you can program it to perform your own specialized editing functions. TECO is such a powerful editing package, that you can actually write programs in it.

**Choice of languages.** Besides the powerful MACRO assembly language that comes with RT-11, DIGITAL also offers a choice of high-level languages. More programmers have worked with these languages on PDP-11 systems than on any other minicomputer or microcomputer system.

The FORTRAN package is a full implementation of the language, with I/O statements, data formatting and data conversion facilities already provided. The powerful real-time capabilities of RT-11 are completely accessible in this language through callable subroutines; object programs are put out in run-time format, without any intermediate assembly. The FORTRAN package automatically segments your programs into read-only and read-write sections for ROM-based microcomputer applications.

Also available are multi-user BASIC, FOCAL, and APL interactive languages.

**Three debugging facilities.** As with editing, debugging a program can be a major part of development. DIGITAL's development systems decrease the time spent on this part of your work, and increase the effectiveness of the time you do spend. Three debugging techniques are available.

ODT (Octal Debugging Technique), standard with RT-11 development software, is an interactive debugger for assembly language programs with full breakpointing and single-step execution facilities.

FDT (FORTRAN Debugging Technique) is an optional debugger for FORTRAN programs. This tool allows the programmer to debug at the FORTRAN statement level, with breakpointing capabilities and type-out of variables in FORTRAN statements.

DDT is a sophisticated symbolic debugger for assembly language programs. It is not offered by DIGITAL, but is available through the DIGITAL Equipment Computer Users Society (DECUS) to its members.

**Existing software.** You may find that some of your development work has already been done, and is available from DIGITAL or DECUS. The world's largest computer users society, DECUS has a special group devoted to LSI-11 microcomputer interests. Programs available to DECUS members include: document preparation utilities; compilers for ALGOL, BLISS, FORTH, and LISP; application modules such as Fast Fourier Transforms, digital signal processing routines, electrical network analysis.

DECUS maintains a program library for PDP-11 and LSI-11 systems, holds regular symposia for its members, and publishes periodicals containing articles and information of interest to DIGITAL customers.

**Development systems.** Two desk-size, PDP-11 based development systems are available, one with floppy disks, and one with disk cartridge drives. Both systems run the RT-11 development software.

The PDP-11V03 is based on the PDP-11/03 microcomputer with 16K words of MOS read/write memory, expandable to 30K words. It has a dual-drive floppy disk, terminator/bootstrap module with DMA refresh, a VT52 DECscope or LA36 DECwriter I/O terminal, and a caster-mounted cabinet with power distribution panel and DLV11 serial interface.

The PDT-11T03-L is the same basic system, but with an RL01 disk cartridge system, instead of the floppy disk. The RL01 disks provide storage capacity of 10.0 megabytes, with an average access time of 30 milliseconds.



PDP-11T03-L development system

Also available: the PDP-11/03, which consists of the LSI-11 microcomputer module with lights, power supply, switches and fan in a rack-mountable enclosure that includes the LSI-11 backplane/card guide assembly for adding family modules of your choice. It comes with either 4K RAM memory, 16K RAM, or 4K core memory. Papertape software packages are offered for use with the PDP-11/03 minicomputer.

### Application services

**Run-time RT-11.** This foreground/background operating system is a subset of the RT-11 development software. It includes facilities for disk file creation, deletion, and renaming, and provides full interrupt-driven support for terminals and serial lines.

**RSX-11S.** This execution-only operating system can handle up to 256 independent tasks through multi-programming priority scheduling. The system provides device handling for non-file structured peripherals.

**SIMRT.** This application feature is part of the FORTRAN package offered for development work. A stand-alone, minimal sized package, it is designed to be used in ROM systems and automatically segments into read-only and read-write sections.

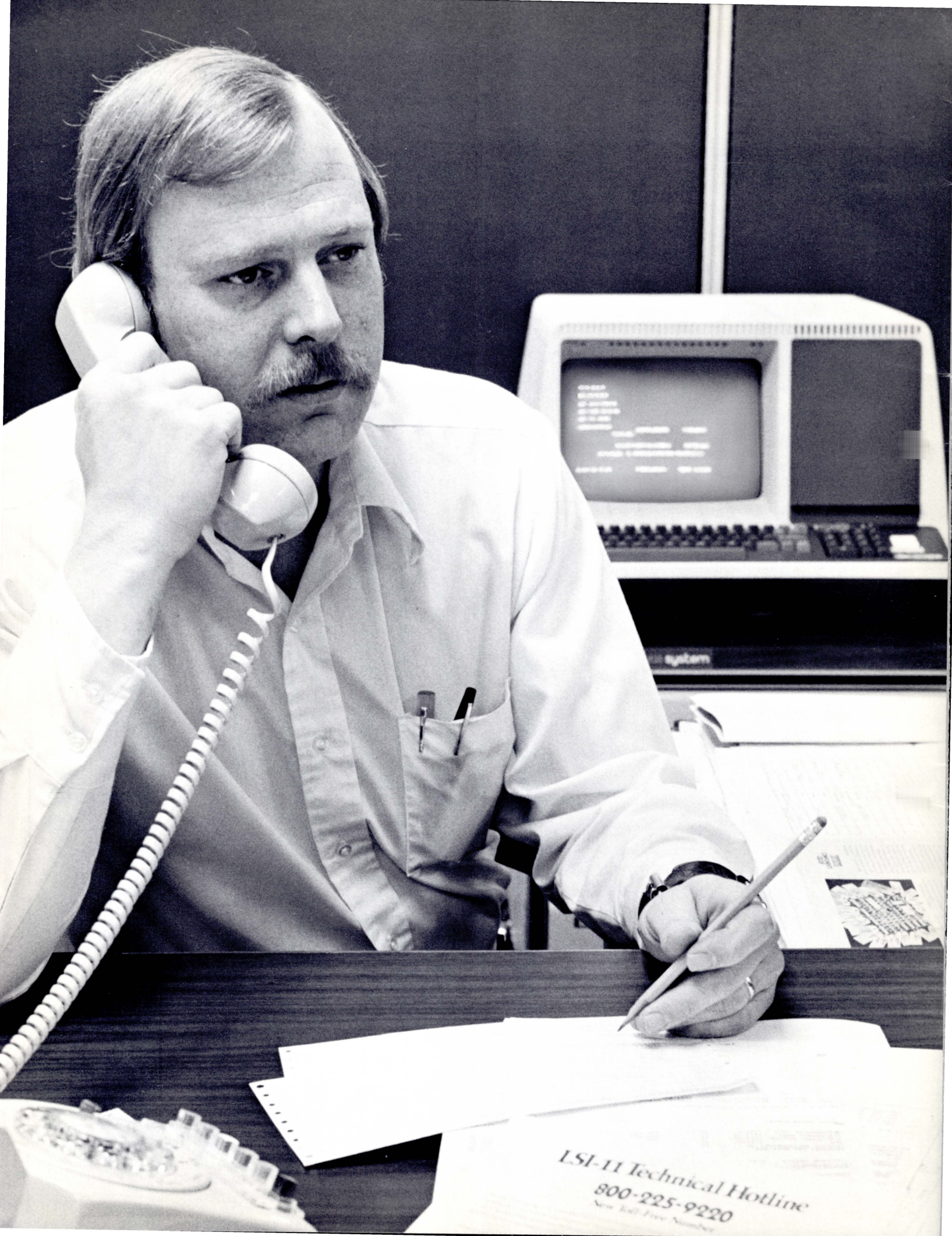

LSI-11 Technical Hotline  
800-225-9220  
New Toll-Free Number

# Support.

The LSI-11 family—the modules, the software, the development systems—are fully supported through DIGITAL's worldwide operations.

This support includes more than simple service. For example, a special Hot Line phone (800-225-9220) is reserved for customers to talk directly to LSI-11 hardware and software specialists. Documentation is complete enough to act as instructional material as well as reference material. And DIGITAL will make every effort to support your own service efforts through a variety of flexible support agreements.

**LSI-11 Technical Hot Line.** The Components Group of DIGITAL provides a toll-free hot line number (800-225-9220). You can call this number anytime between 8:30 a.m. to 5:00 p.m. eastern time to talk to applications engineers about the LSI-11, its family modules, or its software.

**Service.** DIGITAL offers a wide range of maintenance services to LSI-11 customers. These services are provided through DIGITAL's Customer Services Organization and have been designed to meet our customer's complete maintenance needs, either on-site or off-site. These service plans provide complete DIGITAL maintenance on-site by our factory-trained engineers, or provide module and unit repairs off-site for those customers desiring to perform their own maintenance.

**Rapid shipment.** DIGITAL's Components Group is prepared to ship your LSI-11 microcomputer or other family modules within 30-60 days of the receipt of your order. This applies anywhere within the Continental United States.

**Training.** DIGITAL has training resources to meet virtually any customer requirement. Courses can be highly technical, for programmers, or more general, for management.

An example of what's available is the self-paced course on the RT-11 operating system, the major development and run-time software for the LSI-11. The course explains how to use the software tools to write, debug and execute programs in high-level languages under the RT-11 monitor.



**Warranty.** LSI-11 microcomputers are warranted for 90 days. Return any defective unit during this period and it will be repaired or replaced without charge.

**Offices and service centers.**

Corporate Headquarters: Maynard, Massachusetts 01754, Telephone (617) 897-5111. UNITED STATES—ALABAMA, Birmingham, Huntsville • ARIZONA, Phoenix, Tucson • CALIFORNIA, El Segundo,

Oakland, Sacramento, San Diego, San Francisco, Santa Ana, Santa Barbara, Santa Clara • COLORADO, Denver • CONNECTICUT, Fairfield, Meriden • FLORIDA, Miami, Orlando, Tampa • GEORGIA, Atlanta • HAWAII, Honolulu • ILLINOIS, Chicago, Peoria, Rolling Meadows • INDIANA, Indianapolis • IOWA, Bettendorf • KENTUCKY, Louisville • LOUISIANA, New Orleans • MARYLAND, Baltimore, Odenton • MASSACHUSETTS, Springfield, Waltham • MICHIGAN, Detroit • MINNESOTA, Minneapolis • MISSOURI, Kansas City, St. Louis • NEBRASKA, Omaha • NEW HAMPSHIRE, Manchester • NEW JERSEY, Cherry Hill, Fairfield, Princeton, Somerset • NEW MEXICO, Albuquerque, Los Alamos • NEW YORK, Albany, Buffalo, Long Island, Manhattan, Rochester, Syracuse, Westchester • NORTH CAROLINA, Chapel Hill, Charlotte • OHIO, Cincinnati, Cleveland, Columbus, Dayton • OKLAHOMA, Tulsa • OREGON, Portland • PENNSYLVANIA, Harrisburg, Philadelphia, Pittsburgh • RHODE ISLAND, Providence • SOUTH CAROLINA, Columbia • TENNESSEE, Knoxville, Nashville • TEXAS, Austin, Dallas, El Paso, Houston • UTAH, Salt Lake City • VERMONT, Burlington • VIRGINIA, Richmond • WASHINGTON, Seattle • WASHINGTON, D.C. • WEST VIRGINIA, Charleston • WISCONSIN, Milwaukee • INTERNATIONAL—ARGENTINA, Buenos Aires • AUSTRALIA, Adelaide, Brisbane, Canberra, Darwin, Hobart, Melbourne, Perth, Sydney, Tasmania • AUSTRIA, Vienna • BELGIUM, Brussels • BOLIVIA, La Paz • BRAZIL, Rio de Janeiro, Sao Paulo • CANADA, Calgary, Edmonton, Halifax, London, Montreal, Ottawa, Toronto, Vancouver, Winnipeg • CHILE, Santiago • DENMARK, Copenhagen • EGYPT, Cairo • FINLAND, Helsinki • FRANCE, Lyon, Paris • HONG KONG • INDIA, Bombay • INDONESIA, Djakarta • IRAN, Tehran • IRELAND, Dublin • ISRAEL, Tel Aviv • ITALY, Milan, Rome, Turin • JAPAN, Osaka, Tokyo • MALAYSIA, Kuala Lumpur • MEXICO, Mexico City • NETHERLANDS, Amsterdam, Hague, Utrecht • NEW ZEALAND, Auckland, Christchurch • NORTHERN IRELAND, Belfast • NORWAY, Oslo • PERU, Lima • PUERTO RICO, San Juan • SAUDI ARABIA, Jeddah • SCOTLAND, Edinburgh • SINGAPORE • SOUTH KOREA, Seoul • SPAIN, Madrid • SWEDEN, Gothenburg, Stockholm • SWITZERLAND, Geneva, Zurich • TAIWAN, Taipei • UNITED KINGDOM, Birmingham, Bristol, Ealing, Epsom, Leeds, Leicester, London, Manchester, Reading, Welwyn • VENEZUELA, Caracas • WEST GERMANY, Berlin, Cologne, Frankfurt, Hamburg, Hannover, Munich, Nurnberg, Stuttgart • YUGOSLAVIA, Belgrade, Ljubljana •



**digital**  
**COMPONENTS**  
**GROUP**

Digital Equipment Corporation  
One Iron Way  
Marlborough, Massachusetts 01752  
800-225-9220  
Toll-free from 8:30 AM to 5:00 PM\*

In Canada:  
Digital Equipment of Canada Limited  
100 Herzberg Rd.  
P.O. Box 11500  
Kanata, Ontario K2H 8K8  
(613) 592-5111

In Europe:  
Digital Equipment Corporation International (Europe)  
12 av des Morgines  
1213 Petite-Lancy/Geneva  
[41] (22)-93-33-11

\* U.S. only. Massachusetts residents please dial (617) 481-7400. Ext. 5144